

**Kawasaki Robot
B Series (Ver.C)**

**Installation and
Connection Manual**

Robot

Kawasaki Heavy Industries, Ltd.

Preface

This manual describes installation and connection procedures for Kawasaki Robot B Series (Ver. C).

Read and understand the contents of this and safety manuals thoroughly and strictly observe all rules for safety before proceeding with any operation.

This manual describes only the installation and connection of the robot arm. Please refer to the following manual for installation and connection of controller and for arc-welding robots.

“Installation and Connection Manual” for controller

“Installation and Connection Manual” for arc welding

Never proceed with any operation until you understand the contents of this manual completely. Kawasaki cannot take any responsibility for any accidents and/or damages caused by operations that are based on only the limited part of this manual.

This manual is applicable to the following robot arms.

BX100L, BX130X, BX165N, BX165L, BX200L

-
1. This manual does not constitute a guarantee of the systems in which the robot is utilized. Accordingly, Kawasaki is not responsible for any accidents, damages, and/or problems relating to industrial property rights as a result of using the system.
 2. It is recommended that all personnel assigned for activation of operation, teaching, maintenance or inspection of the robot attend the necessary education/training course(s) prepared by Kawasaki, before assuming their responsibilities.
 3. Kawasaki reserves the right to change, revise, or update this manual without prior notice.
 4. This manual may not, in whole or in part, be reprinted or copied without the prior written consent of Kawasaki.
 5. Store this manual with care and keep it available for use at any time. If the robot is reinstalled or moved to a different site or sold off to a different user, attach this manual to the robot without fail. In the event the manual is lost or damaged severely, contact Kawasaki.
-

Applicable Robots

This manual is applicable to B Series (Ver. C) robots. Check the supporting structure of the gas spring and the machine nameplate to know if the robot is B Series (Ver. C) or not.

B series (Ver. C) robots

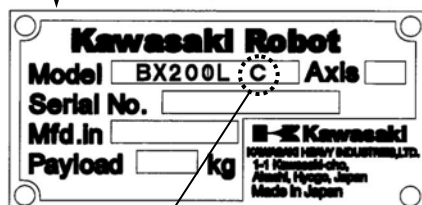
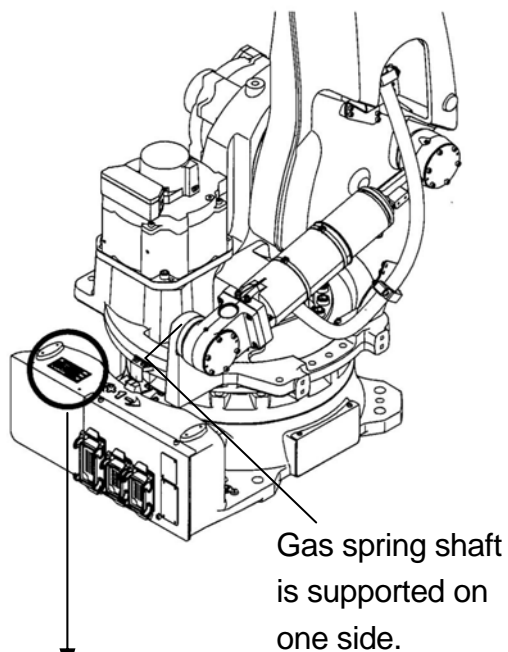

“C” is written in the Model column.

Robots other than B series (Ver. C)

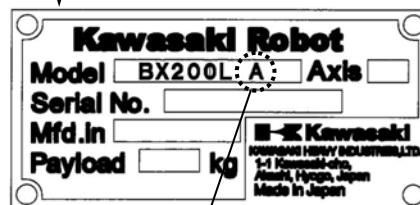
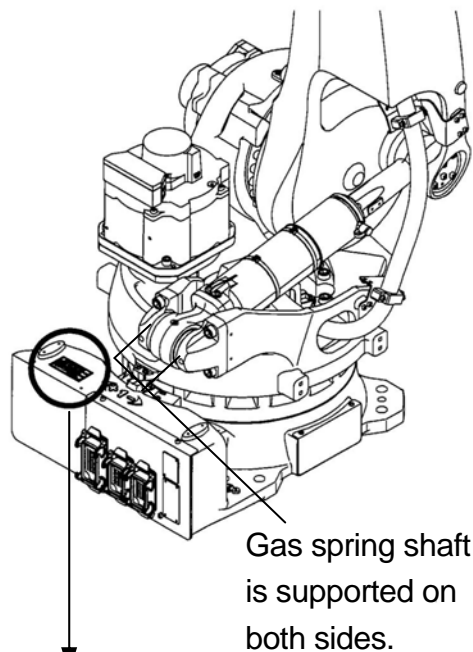

Kawasaki Robot	
Model	BX200L: B Axis
Serial No.	
Mfd.in	
Payload	kg
<small>川崎重工業株式会社 1-1 Kawasaki-cho, Maatsi, Hyogo, Japan Made in Japan</small>	

“A” or “B” is written in the Model column.

Symbols

The items that require special attention in this manual are designated with the following symbols.

Ensure proper and safe operation of the robot and prevent physical injury or property damages by complying with the safety matters given in the boxes with these symbols.

 **DANGER**

Failure to comply with indicated matters can result in imminent injury or death.

 **WARNING**

Failure to comply with indicated matters may possibly lead to injury or death.

 **CAUTION**

Failure to comply with indicated matters may lead to physical injury and/or mechanical damage.

[NOTE]

Denotes precautions regarding robot specification, handling, teaching, operation, and maintenance.

 **WARNING**

- 1. The accuracy and effectiveness of the diagrams, procedures, and detail explanations given in this manual cannot be confirmed with absolute certainty. Should any unexplained questions or problems arise, contact Kawasaki.**
- 2. Safety related contents described in this manual apply to each individual work and not to all robot work. In order to perform every work in safety, read and fully understand the safety manual, all pertinent laws, regulations and related materials as well as all the safety explanation described in each chapter, and prepare safety measures suitable for actual work.**

Table of Contents

Preface	i
Applicable Robots.....	ii
Symbols.....	iii
1 Precautions	1
1.1 Precautions during Transportation, Installation and Storage.....	1
1.2 Installing Environment of Robot Arm	2
1.3 Residual Risks during Work.....	3
2 Work Flow at Arm Installation and Connection.....	5
3 Motion Range and Specifications of Robot	6
3.1 Determination of Safety Fence Installation Location	6
3.2 Motion Range and Specifications of Robot	7
3.3 Mechanical Stoppers.....	12
3.3.1 JT1 Stopper Block.....	13
4 Robot Transportation Method	15
4.1 Using Wire Sling.....	15
4.2 Forklift.....	18
5 Installation Dimensions of Base Section.....	19
6 Movement Reaction Acting on Installation Surface during Operation.....	20
7 Installation Method	21
7.1 When Installing the Base Directly on the Floor.....	21
8 Mounting of Tools	22
8.1 Dimensions of Wrist End.....	22
8.2 When passing cable/hose through Wrist Hollow Section	22
8.3 Specification of Mounting Bolt	23
8.4 Load Capacity	24
9 Mounting External Equipment	28
9.1 Service Tapped Hole Positions.....	28
9.2 Calculation of Load Caused by External Equipment	29

1 Precautions

1.1 Precautions during Transportation, Installation and Storage

When transporting the Kawasaki Robot to its installation site, strictly observe the following cautions.



WARNING

1. When the robot arm is to be transported by using a crane or forklift, never support the robot arm manually.
2. During transportation, never climb on the robot arm or stay under the hoisted robot arm.
3. Prior to installation, turn OFF the controller power switch and the external power switch for shutting down power supply to the controller. Display signs indicating clearly “Installation and connection in progress”, and lockout/tagout the external power switch to prevent accidents of electric shock etc. caused when someone accidentally turns ON the power.
4. Prior to moving robot, ensure safety by first confirming no abnormality is observed in installing condition, etc., and then turn ON motor power to set robot to the desired pose. Be careful not to be caught by/between any moving parts due to careless approach to robot and peripheral equipment. After setting robot to the specified pose, turn OFF the controller power and the external power switch again as mentioned above. Display signs indicating clearly “Installation and connection in progress”, and lockout/tagout the external power switch before starting installation and connection.



CAUTION

1. Since the robot arm is composed of precision parts, be careful not to apply excessive shocks or vibrations during transportation.
2. Prior to transporting the robot, remove all obstacles so the installation is carried out smoothly and safely.
3. During transportation and storage,
 - (1) Keep the ambient temperature within the range of minus 10 to 60°C,
 - (2) Keep the relative humidity within the range of 35 to 85% RH without dew condensation,
 - (3) Keep free from excessively strong vibration.

1.2 Installing Environment of Robot Arm

The robot arm must be installed in a place that satisfies all the following environmental conditions:

1. When robot is installed on the floor, the levelness must be within $\pm 5^\circ$.
2. Be sure that the installation floor/pedestal has sufficient rigidity.
3. Secure a flatness to prevent undue force applied to the installation section. (If sufficient flatness is unobtainable, insert liners and adjust the flatness. Flatness of installing surface: 0.3 or less)
4. Keep the ambient temperature during operation within the range of 0 to 45 °C. (Deviation or overload error may occur due to high viscosity of grease/oil when starting operation at low temperatures. In this case, move the robot at low speed before regular operation.)
5. Keep the relative humidity during operation within the range of 35 to 85%RH without dew condensation.
6. The robot installing place should be free from dust, dirt, oil, smoke, water, and other foreign matters.
7. The robot installing place should be free from flammable or corrosive liquid or gas.
8. The robot installing place should be free from excessively strong vibration. (0.5 G or less)
9. The robot installing place should be free from electric noise interference.
10. The robot installing place should be sufficiently larger than the motion range of robot arm.
 - (1) Install safety fence so the maximum movement of fully equipped robot arm (with tools and workpieces) does not cause interference.
 - (2) Minimize the number of entrance gates of the safety fence (only one is best) and equip the entrance gate with a safety plug.
 - (3) Observe the requirements of ISO 10218, etc. established in each region for details of the safety fence.

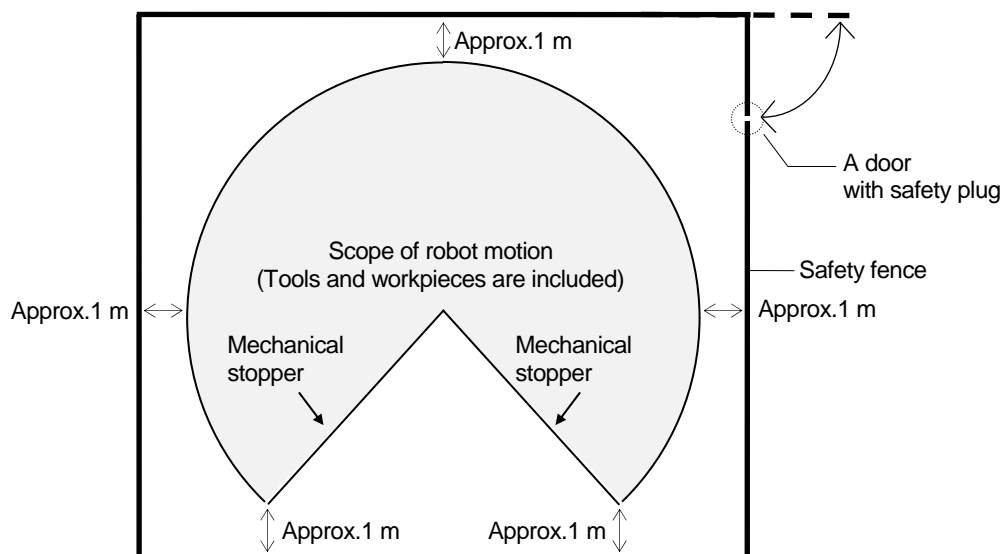

1.3 Residual Risks during Work

! **WARNING**

Pay attention to the hazardous places listed in the drawings below.

Hazardous places for high temperature and electric shock (BX100L, BX130X, BX165N, BX165L, BX200L)

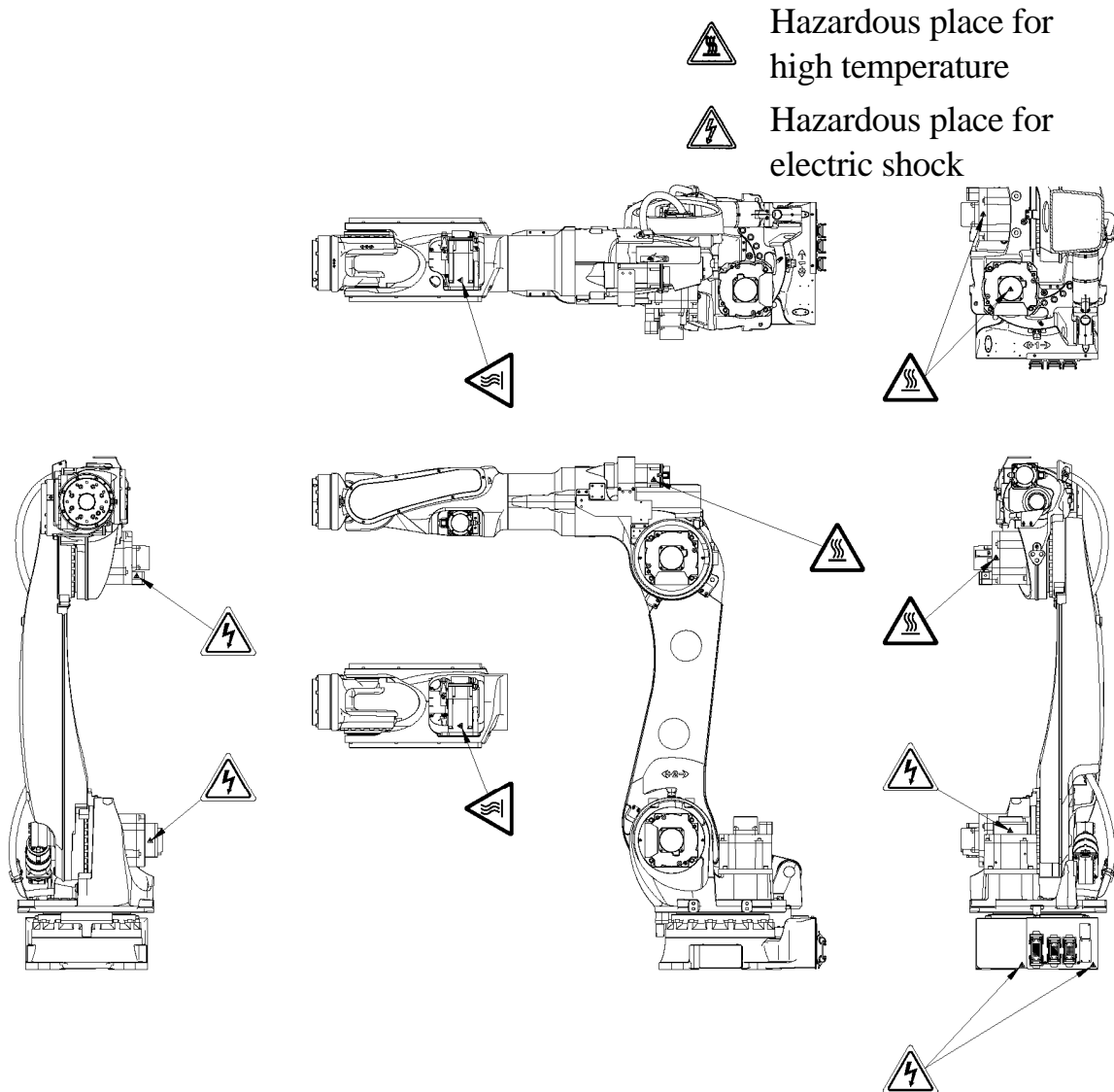

Hazardous places for pinching (BX100L, BX130X, BX165N, BX165L, BX200L)

○ Hazardous place for pinching

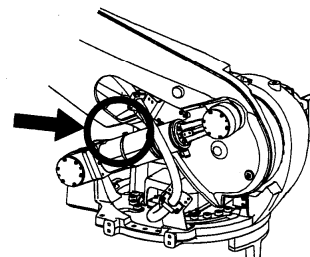
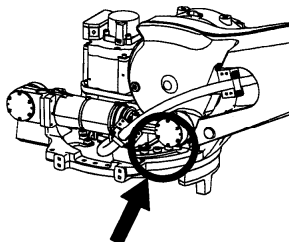
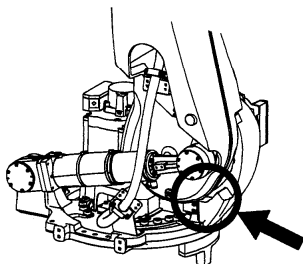
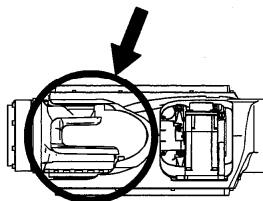
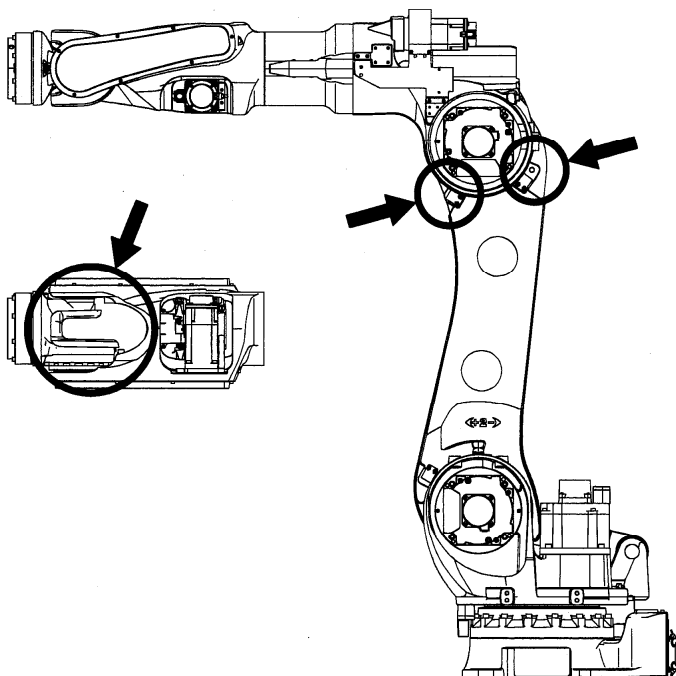
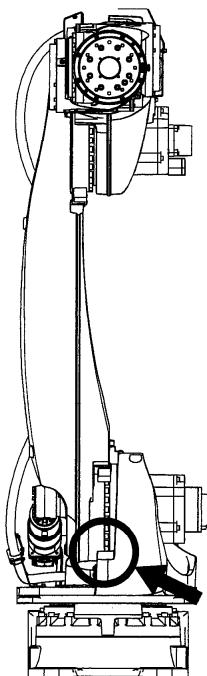
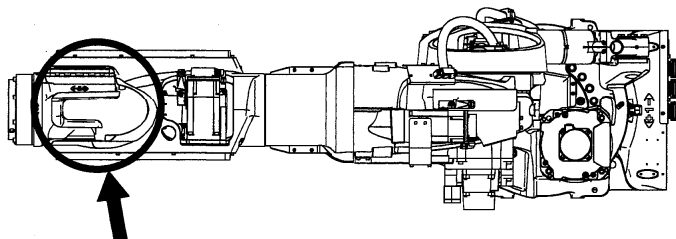

2 Work Flow at Arm Installation and Connection

This workflow describes only the robot arm section. For the controller, refer to “Installation and Connection Manual” for controller.

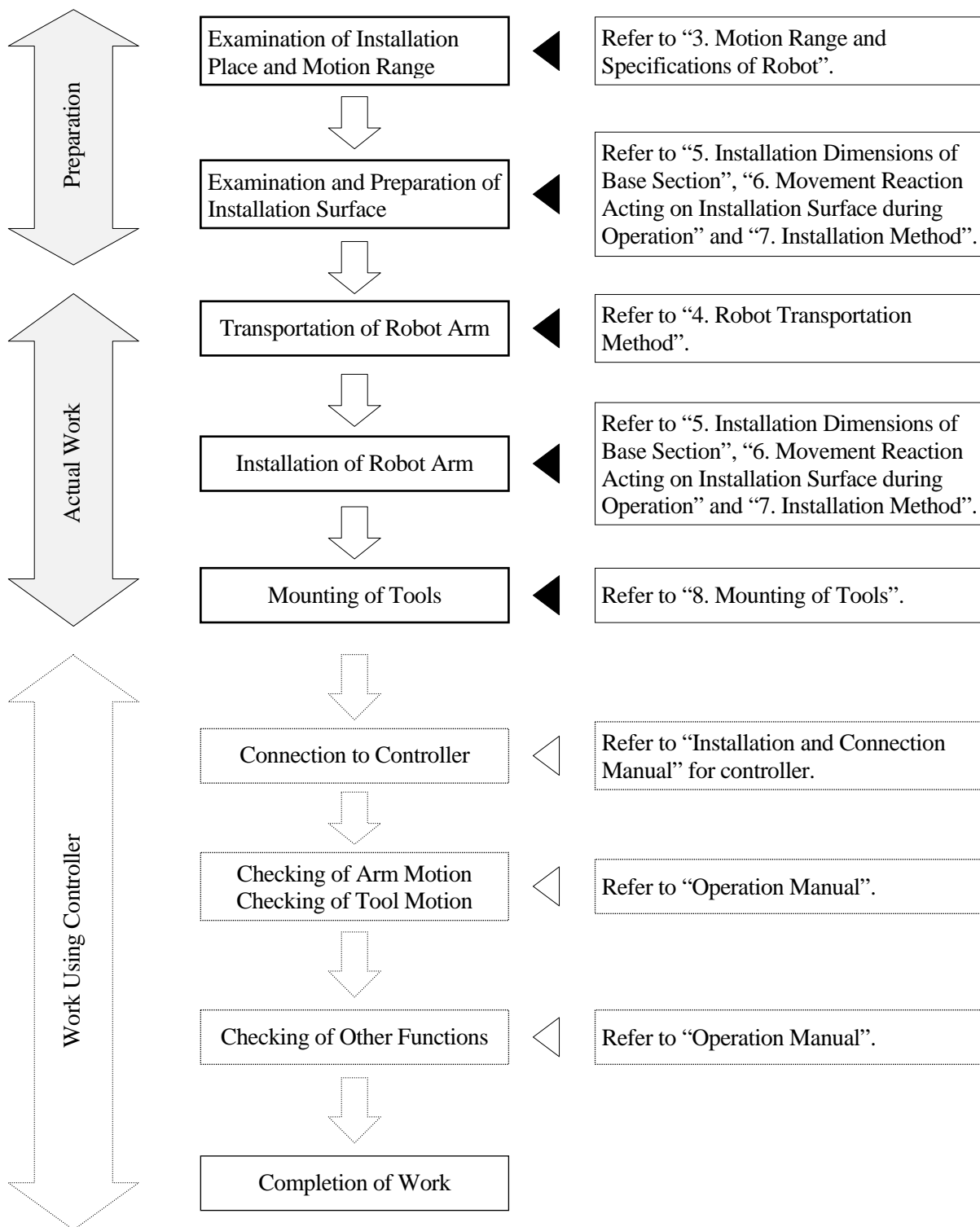

3 Motion Range and Specifications of Robot

3.1 Determination of Safety Fence Installation Location

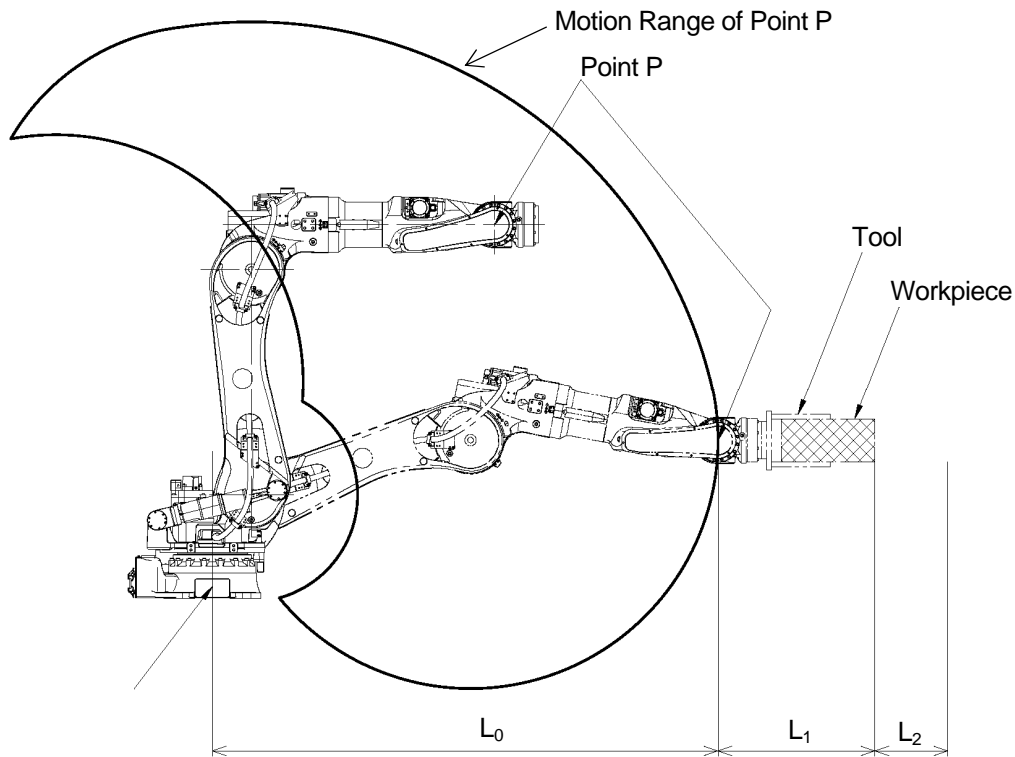

The motion range of the robot is represented by the maximum area that can be covered by point P in the figure above. Therefore, as shown in the figure below, install the safety fence outside circle whose radius is $L_0+L_1+L_2$. Where; L_0 is the length from the center line of arm (point A shown above) to the farthest point of P, L_1 is the length from point P to the farthest point of wrist flange, tool and workpiece, and L_2 is safety margin. For the length of L_0 , refer to the drawings in the section 3.2.

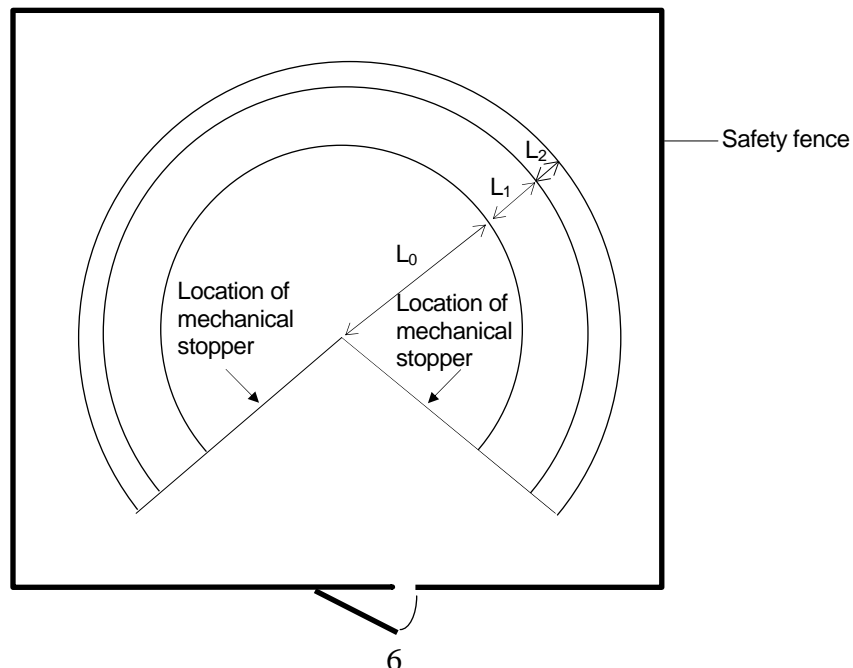

3.2 Motion Range and Specifications of Robot

BX100L

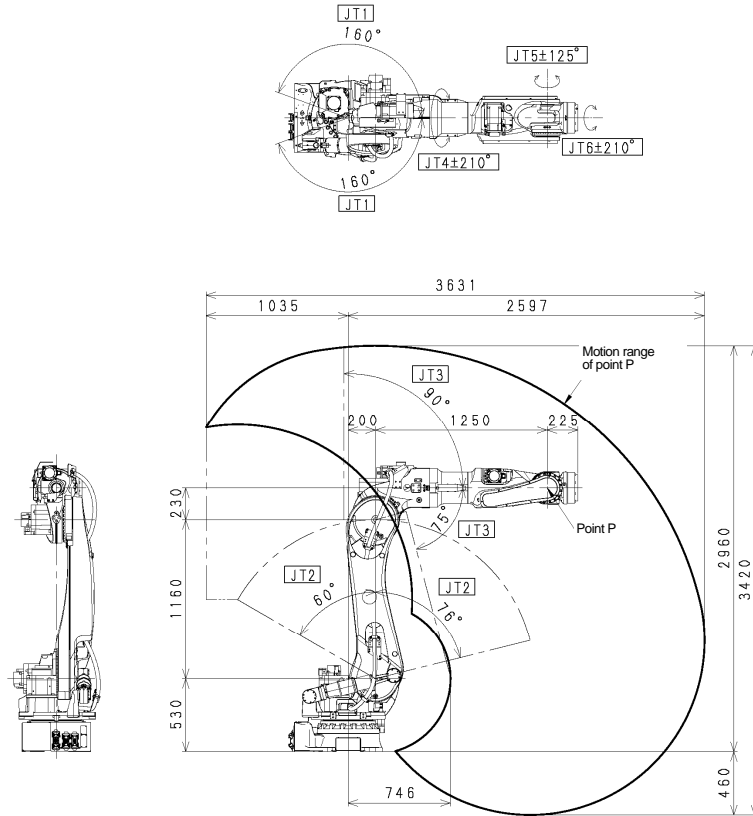

Type	Vertical Articulated Robot		
Degree of Freedom	6		
Motion Range and Maximum Speed	JT	Motion Range	Max. Speed
	1	±160°	105 °/s
	2	+76° to -60°	130 °/s
	3	+90° to -75°	130 °/s
	4	±210°	200 °/s
	5	±125°	160 °/s
6	±210°	300 °/s	
Max. Payload	100 kg		
Wrist Load Capacity	JT	Torque	Moment of Inertia
	4	830 N·m	85 kg·m ²
	5	830 N·m	85 kg·m ²
6	441 N·m	45 kg·m ²	
Repeatability	±0.06 mm		
Mass	890 kg		
Acoustic Noise	<80 dB (A)*		

*measured condition

- installed on the plate rigidly fixed on the floor
- 4600 mm away from JT1 center

The noise level depends on the conditions.

BX130X

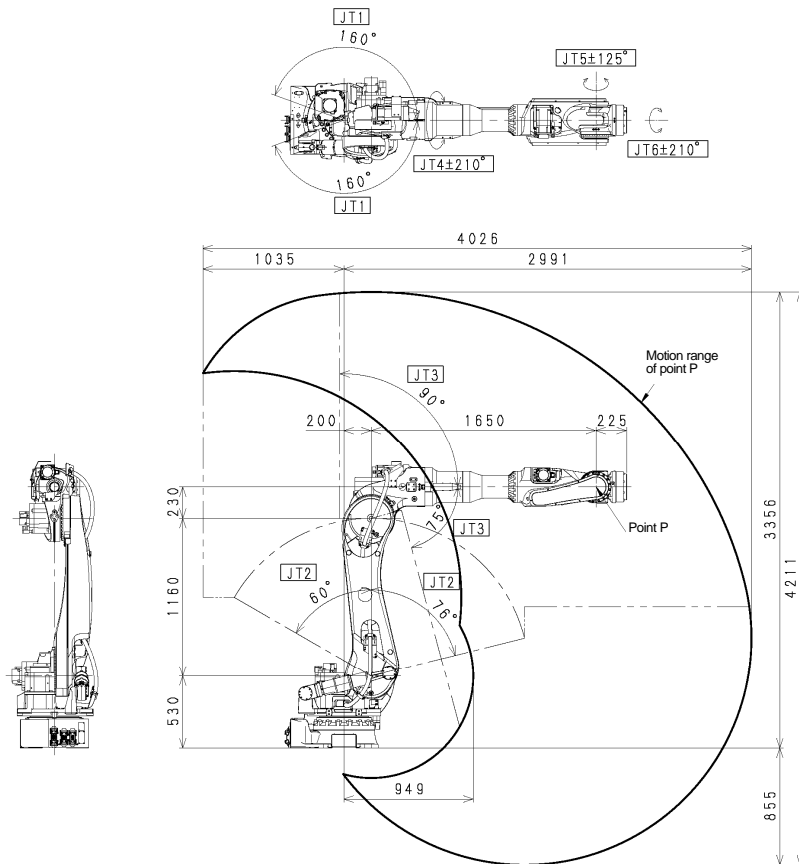

Type	Vertical Articulated Robot		
Degree of Freedom	6		
Motion Range and Maximum Speed	JT	Motion Range	Max. Speed
	1	±160°	105 °/s
	2	+76° to -60°	90 °/s
	3	+90° to -75°	130 °/s
	4	±210°	200 °/s
	5	±125°	160 °/s
6	±210°	300 °/s	
Max. Payload	130 kg		
Wrist Load Capacity	JT	Torque	Moment of Inertia
	4	830 N·m	85 kg·m ²
	5	830 N·m	85 kg·m ²
6	441 N·m	45 kg·m ²	
Repeatability	±0.06 mm		
Mass	920 kg		
Acoustic Noise	< 80 dB (A)*		

*measured condition

- installed on the plate rigidly fixed on the floor
- 5000 mm away from JT1 center

The noise level depends on the conditions.

BX165N

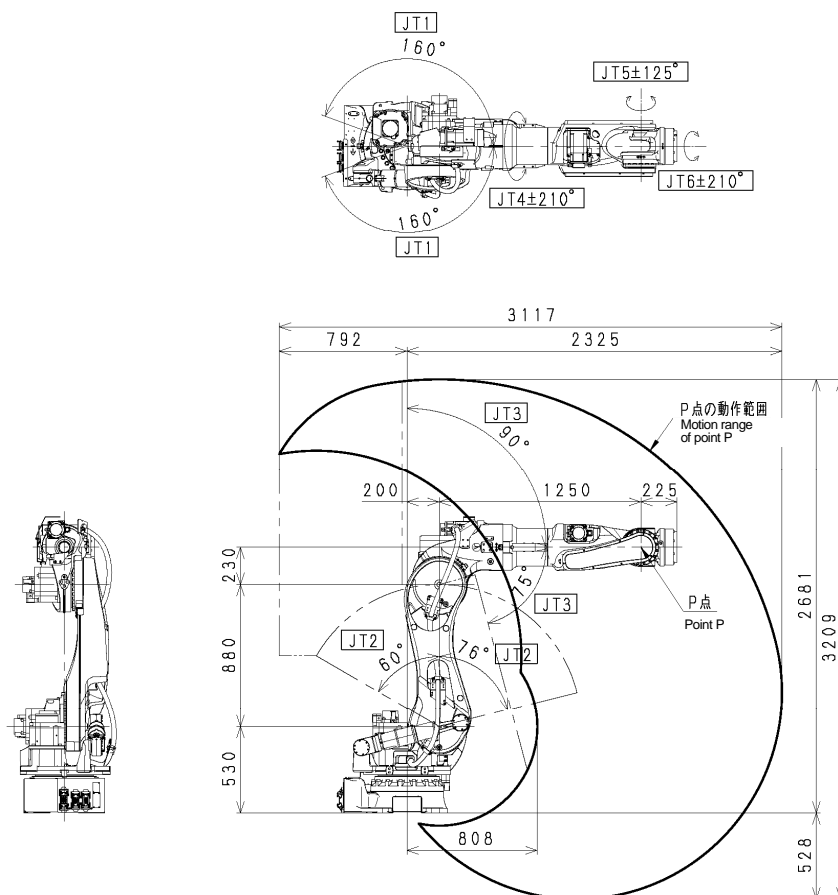

Type	Vertical Articulated Robot		
Degree of Freedom	6		
Motion Range and Maximum Speed	JT	Motion Range	Max. Speed
	1	±160°	105 °/s
	2	+76° to -60°	130 °/s
	3	+90° to -75°	130 °/s
	4	±210°	120 °/s
	5	±125°	160 °/s
6	±210°	300 °/s	
Max. Payload	165 kg		
Wrist Load Capacity	JT	Torque	Moment of Inertia
	4	930 N·m	99 kg·m ²
	5	930 N·m	99 kg·m ²
6	490 N·m	49.5 kg·m ²	
Repeatability	±0.06 mm		
Mass	875 kg		
Acoustic Noise	< 80 dB (A)*		

*measured condition

- installed on the plate rigidly fixed on the floor
- 4300 mm away from JT1 center

The noise level depends on the conditions.

BX165L

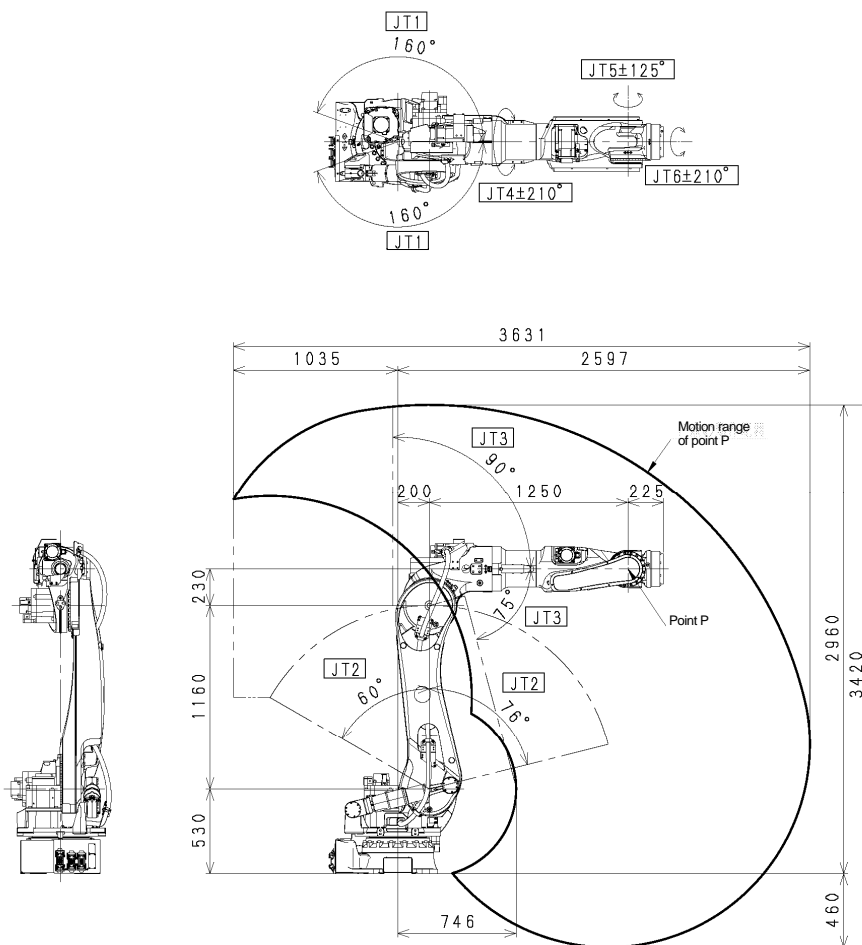

Type	Vertical Articulated Robot		
Degree of Freedom	6		
Motion Range and Maximum Speed	JT	Motion Range	Max. Speed
	1	±160°	120 °/s
	2	+76° to -60°	110 °/s
	3	+90° to -75°	130 °/s
	4	±210°	170 °/s
	5	±125°	170 °/s
Max. Payload	165 kg		
Wrist Load Capacity	JT	Torque	Moment of Inertia
	4	952 N·m	99 kg·m ²
	5	952 N·m	99 kg·m ²
	6	491 N·m	49.5 kg·m ²
Repeatability	±0.06 mm		
Mass	890 kg		
Acoustic Noise	< 80 dB (A)*		

*measured condition

- installed on the plate rigidly fixed on the floor
- 4600 mm away from JT1 center

The noise level depends on the conditions.

BX200L

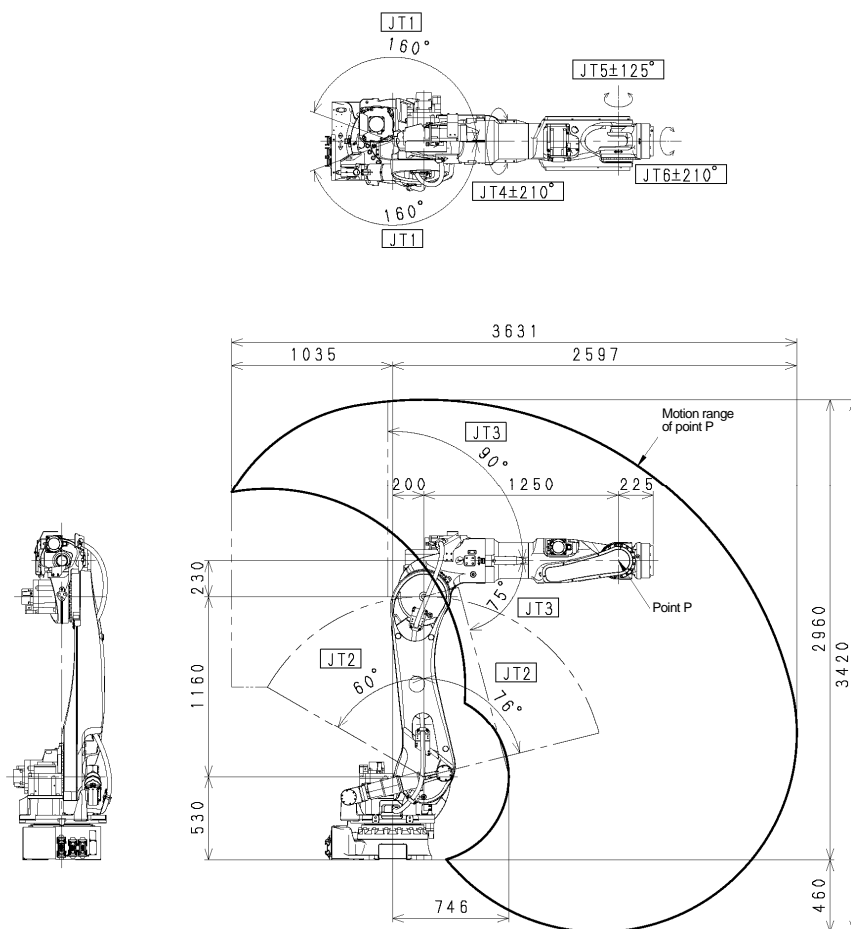

Type	Vertical Articulated Robot		
Degree of Freedom	6		
Motion Range and Maximum Speed	JT	Motion Range	Max. Speed
	1	±160°	105 °/s
	2	+76° to -60°	90 °/s
	3	+90° to -75°	100 °/s
	4	±210°	120 °/s
	5	±125°	120 °/s
6	±210°	200 °/s	
Max. Payload	200 kg		
Wrist Load Capacity	JT	Torque	Moment of Inertia
	4	1334 N·m	199.8 kg·m ²
	5	1334 N·m	199.8 kg·m ²
6	588 N·m	154.9 kg·m ²	
Repeatability	±0.06 mm		
Mass	890 kg		
Acoustic Noise	< 80 dB (A)*		

*measured condition

- installed on the plate rigidly fixed on the floor
- 4600 mm away from JT1 center

The noise level depends on the conditions.

3.3 Mechanical Stoppers

For JT1, JT2 and JT3 of base axes, mechanical stoppers are mounted at the places shown in the figure below. Among them, the motion range of JT1 can be changed by changing the mounting position of stopper block of stopper member on the moving side.

However, when the motion range is changed, it is necessary to change the motion range limits to the corresponding values by Auxiliary function 0507.

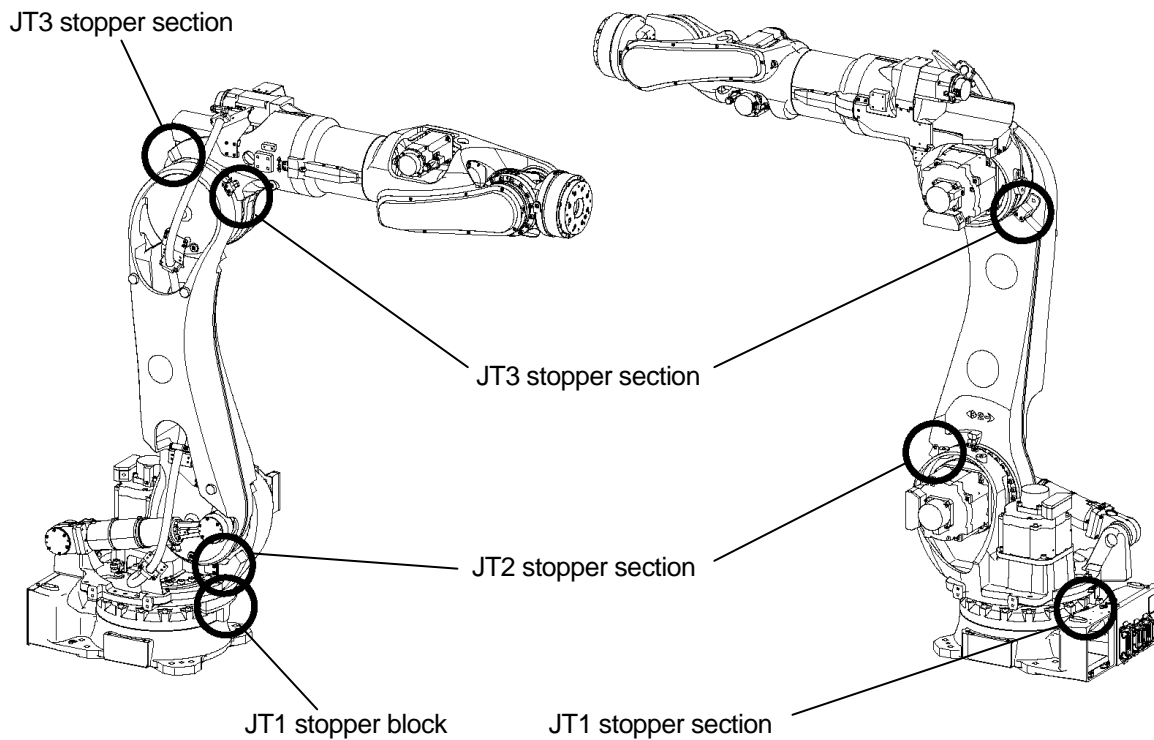

3.3.1 JT1 Stopper Block

Mounting position of JT1 stopper block can be changed by angular unit of 10 degrees. In addition, reducing the motion range is possible by mounting two stopper blocks as an option.

When mounting a stopper block:

Stopper block mounting position can only be changed within the motion range of 180° on both plus and minus sides due to the restriction from control and harness treatment. Total motion range of both plus and minus sides is 320° .

Mounting a stopper block as shown below makes the motion range of 180° on the plus side and 140° on the minus side.

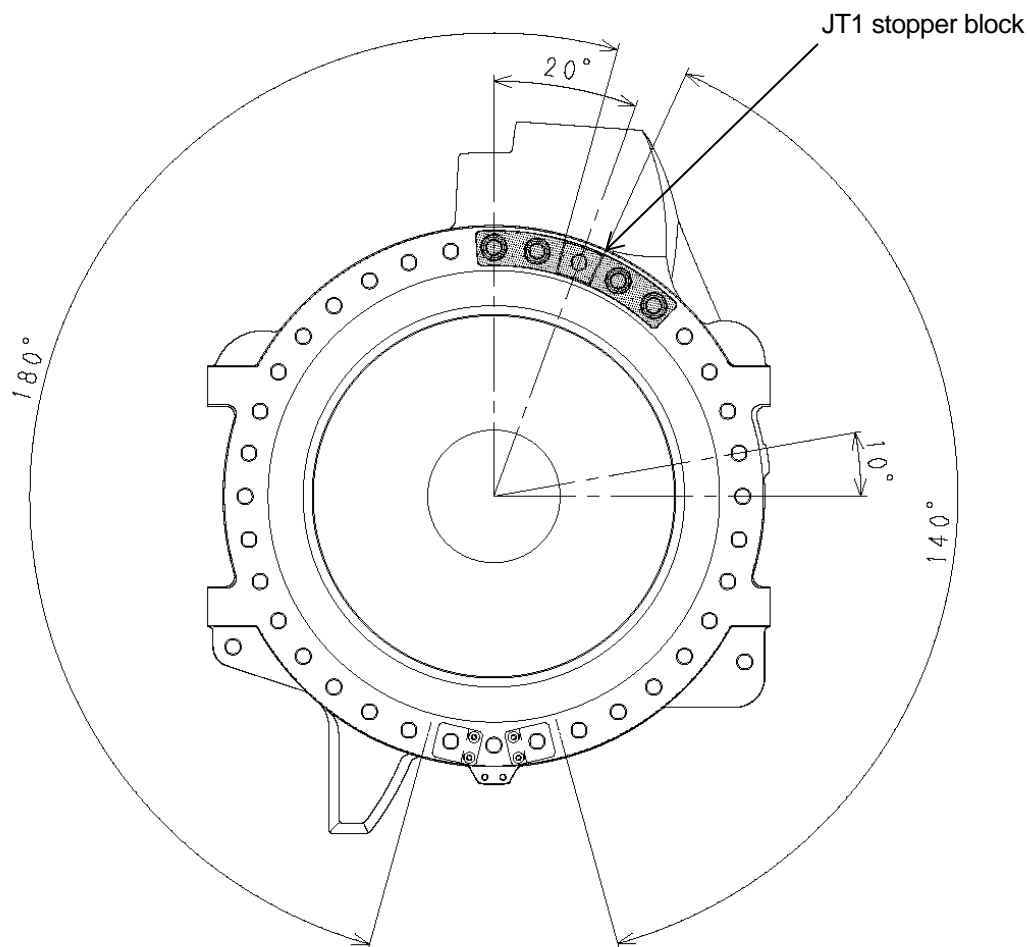

When mounting two stopper blocks:

Stopper blocks mounting positions can only be changed within the motion range of 180° on both plus and minus sides due to the restriction from control and harness treatment. However, the total motion range of both plus and minus sides is between 10° and 270° .

Mounting stopper blocks as shown below makes the motion range of 130° on the plus side and 140° on the minus side.

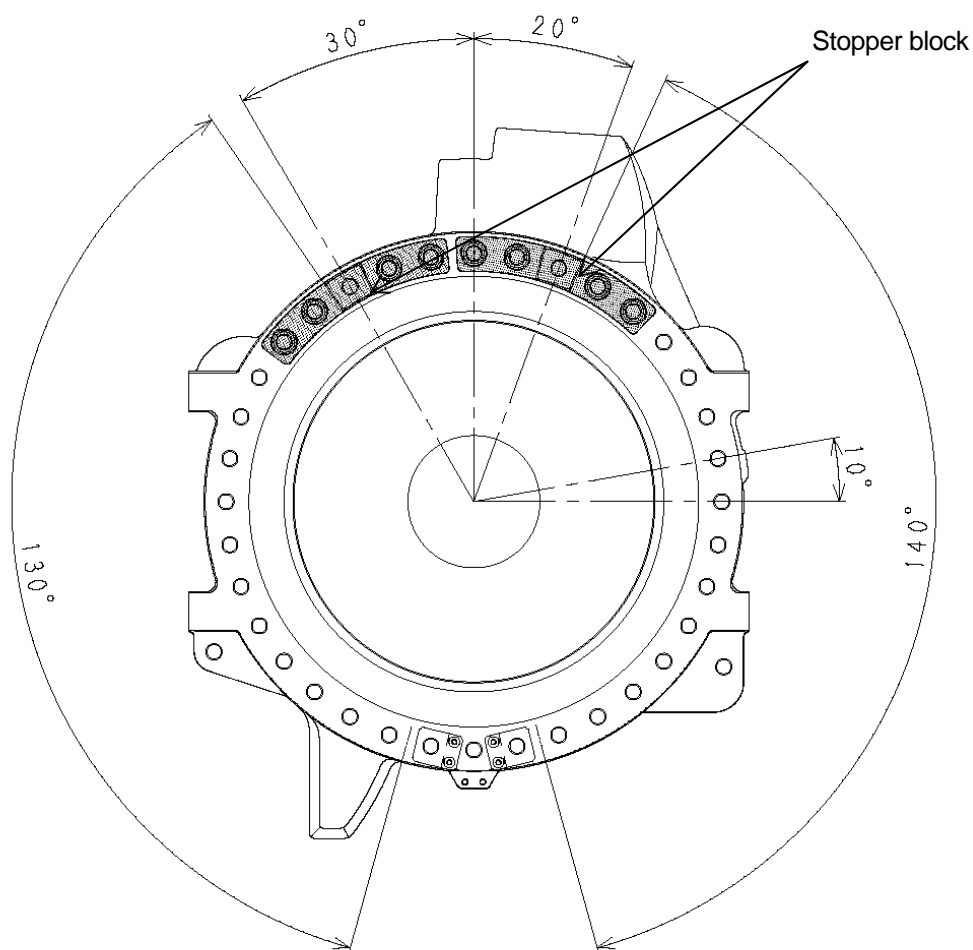

4 Robot Transportation Method

4.1 Using Wire Sling

As shown in the figure below, attach two hoisting jigs on robot arm and hoist up the robot with wire slings by hooking onto a hook part of the robot and the two hoisting jigs. (Manufactured by TAIYO, Product name: V-hook, Nominal working load: 1.25t or equivalent) Refer to the figure on page 19 to attach the hoisting jigs.



WARNING

Use a hoisting jig without fail when hoisting up robot. If the robot is hoisted up without using the jig, robot may fall.



CAUTION

When hoisting up the robot, be careful as robot may lean forward/backward depending on robot posture and installation condition of the options. If the robot is hoisted up in an inclined posture, it may swing, damage or the wire may interfere with the harness, piping etc., or it may damage due to interfering with surrounding objects. Remove the hoisting jig attached to the arm once the transportation of robot is complete.

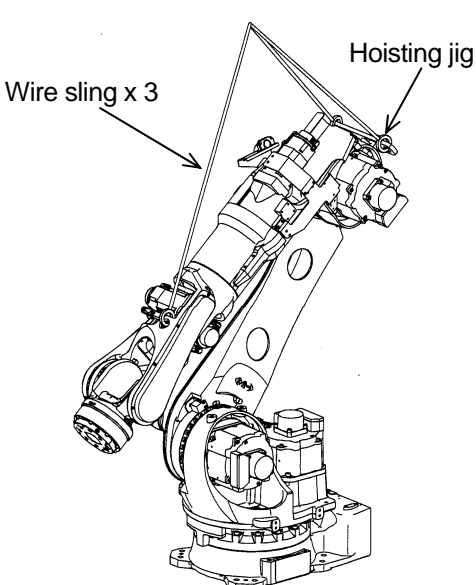
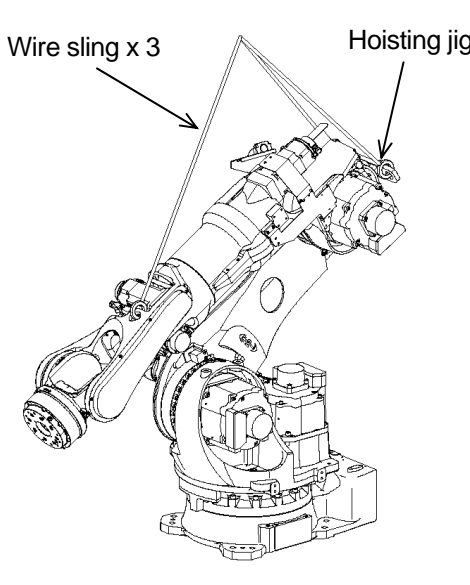
Model		BX100L, BX130X, BX165L, BX200L	BX165N
Hoisted up posture			
Hoisted up posture	JT1	0°	0°
	JT2	-35°	-45°
	JT3	-75°	-75°
	JT4	0°	0°
	JT5	0°	0°
	JT6	0°	0°

Attach the hoisting jig as shown in the figure below.

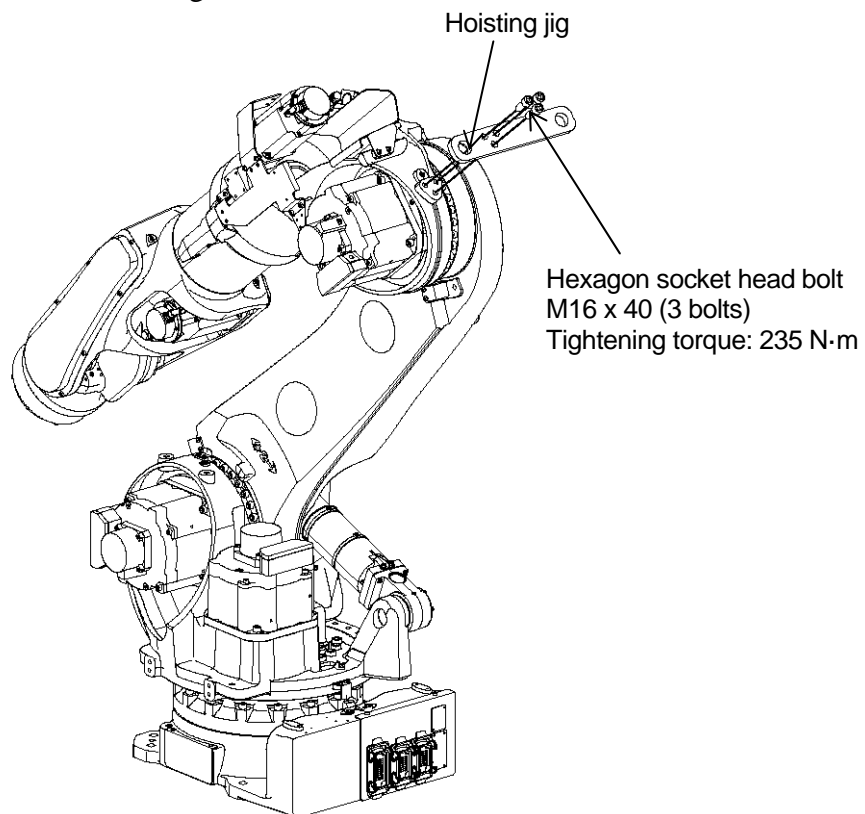

4.2 Forklift

Attach the transportation jig for forklift to the robot arm as shown in the figure below and transport the robot by using the jig.



CAUTION

1. Check if a fork of the forklift penetrates the transportation jig sufficiently without fail.
2. When transporting robot on an inclined or rough surface, be careful to maintain balance to prevent forklift/robot from falling.
3. Remove the transportation jig attached to the arm once the transportation of robot is complete.

BX100L, BX130X, BX165N, BX165L, BX200L

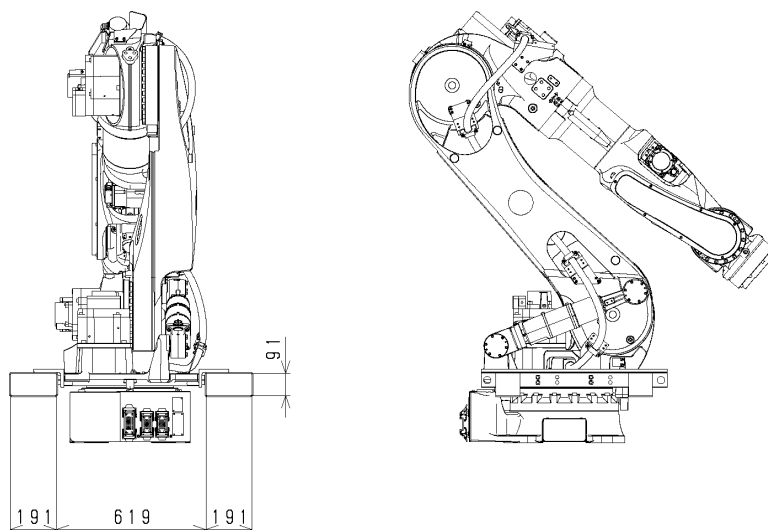

Transportation jig for forklift

Hexagon socket head bolt
M12 x 35 (8 bolts)
Tightening torque: 98 N·m

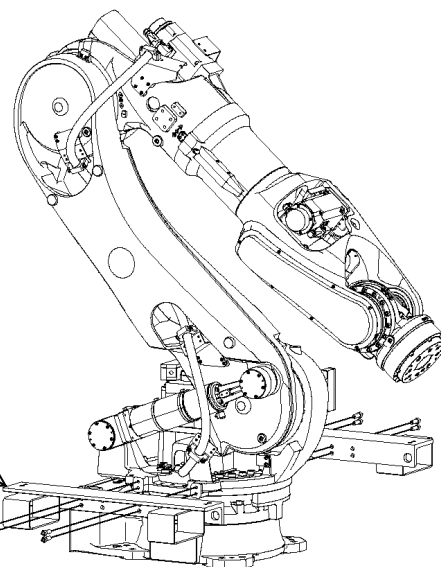

5 Installation Dimensions of Base Section

When installing a robot, fix the base section with high tension bolts through the bolt holes.

Model	BX100L, BX130X, BX165N, BX165L, BX200L
Dimensions for installation	
Cross-section of installation section	
Bolt hole	8-φ22
High tension bolt	8-M20 Material: SCM435 Strength class: 10.9 min.
Tightening torque	431 N·m
Levelness	Within ±5°

6 Movement Reaction Acting on Installation Surface during Operation

Refer to the list below for the movement reaction that acts on the installation surface during operation. Consider these values at installation.

Model	BX100L, BX130X, BX165L, BX200L	BX165N
M (Inversion Moment N·m)	35000	33400
T (Rotating Torque N·m)	15000	13000

See the next chapter for M and T

7 Installation Method

7.1 When Installing the Base Directly on the Floor

In this case, bury steel plate (35 mm min. thickness) in the concrete floor as shown in the figure below or fix it with anchors. Fix the steel plate firmly enough to endure the reaction forces produced by the robot.

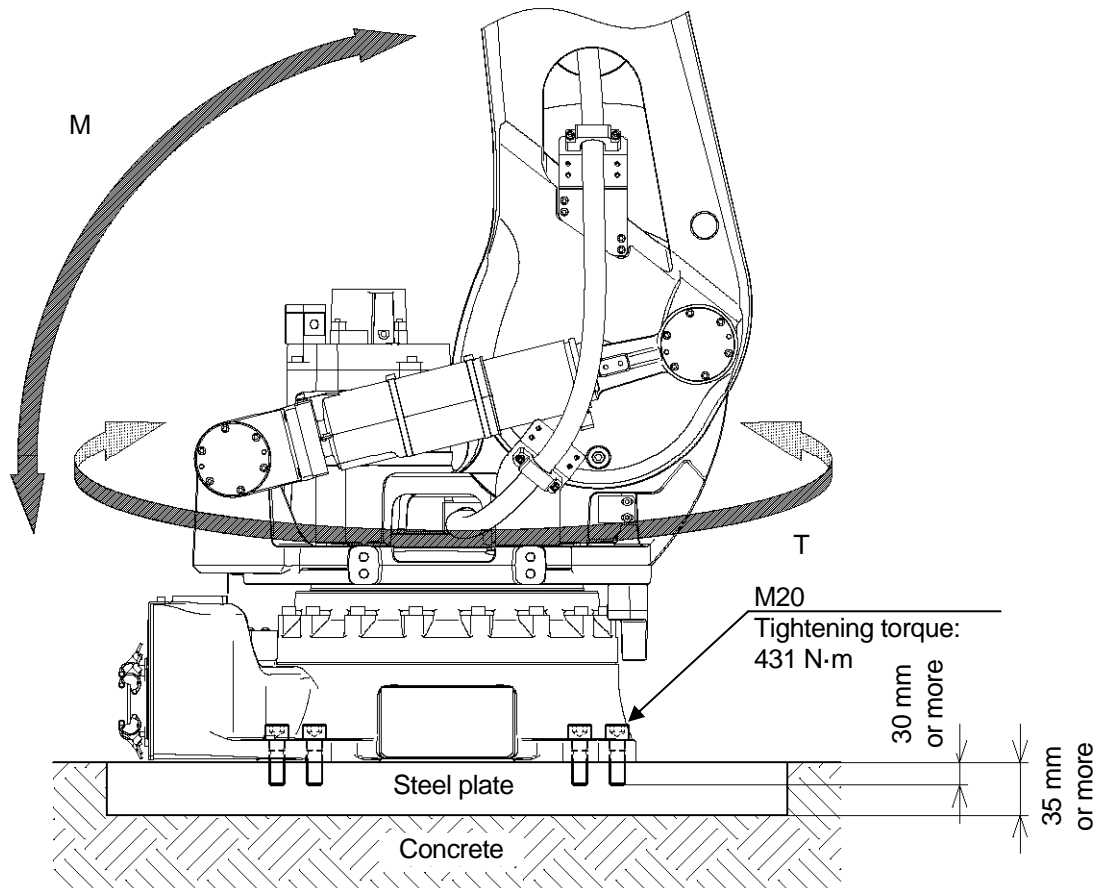

8 Mounting of Tools

! WARNING

Prior to mounting tools on the robot, turn OFF the controller power switch and the external power switch. Display signs indicating clearly “Installation and connection in progress”, and lockout/tagout the external power switch to prevent personnel from accidentally turning ON the power.

8.1 Dimensions of Wrist End

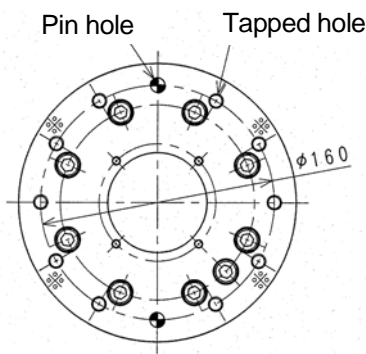

In the robot arm end section, a flange is provided on which hand, gun, or other tools are mounted. Screw the mounting bolts into the tapped holes on the circumference of $\phi 160$ on the flange, referring to the figure on the left. Moreover, position the tool by utilizing the pin holes.

8.2 When passing cable/hose through Wrist Hollow Section

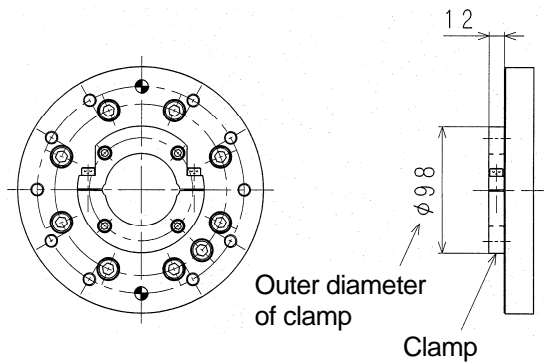

When passing a cable/hose through the wrist hollow section, clamp is attached on the wrist flange as shown in the left figure. Provide a hole of $\phi 100$ on the flange of the tool side, or use an optional adapter plate or an adaptor bracket (option).

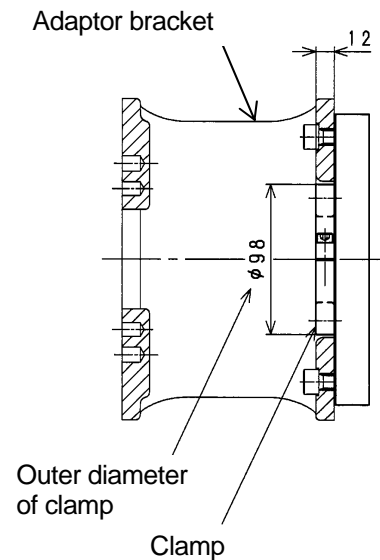
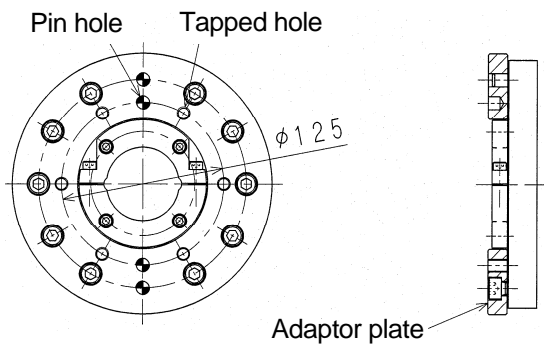

8.3 Specification of Mounting Bolt

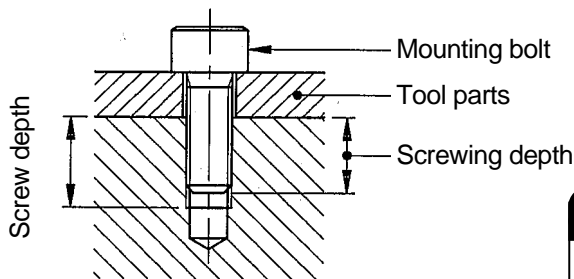

Select mounting bolts with proper length to secure the specified screwing depth according to the tapped depth of tool mounting flange. Use high tension mounting bolts and tighten them to the specified torque.

! caution

If the screwing depth has exceeded the specified value, the mounting bolt might bottom out, and the tool will not be fixed securely.

	Standard flange	Optional flange (Adaptor plate)
Model	B series (Ver. C)	B series (Ver. C)
Tapped hole	6-M10	6-M10
ϕD	$\phi 160$	$\phi 125$
Pin hole	2- $\phi 10H7$ Depth 12	2- $\phi 10H7$ Depth 14
Screw depth	19 mm	20 mm
Screwing depth	13 to 14 mm	13 to 14 mm
High tension bolt	SCM435, 10.9 min	SCM435, 10.9 min
Tightening torque	56.84 N·m	56.84 N·m

	Optional flange (Adaptor bracket)		
Model	B series (Ver. C)		
Tapped hole	10-M10	6-M10*	6-M10*
ϕD	$\phi 92$	$\phi 125$	$\phi 160$
Pin hole	2- $\phi 9H7$ Depth 12	2- $\phi 10H7$ Depth 12	2- $\phi 10H7$ Depth 12
Screw depth	12 mm (through)	12 mm (through)	12 mm (through)
Screwing depth	13 to 18 mm	13 to 18 mm	13 to 18 mm
High tension bolt	SCM435, 10.9 min	SCM435, 10.9 min	SCM435, 10.9 min
Tightening torque	56.84 N·m	56.84 N·m	56.84 N·m

NOTE* No need to use the tapped holes with ☆ in the figures below.

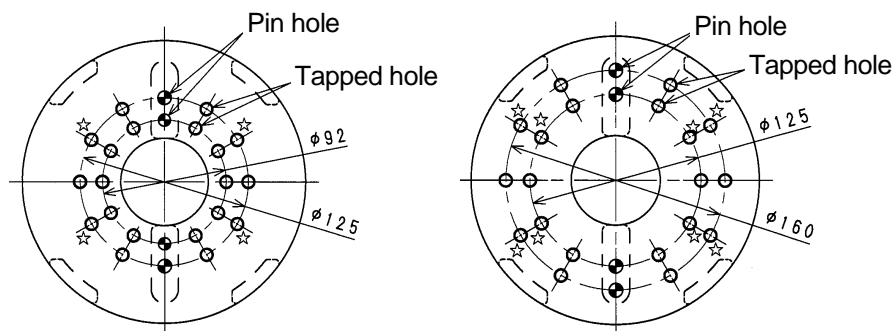

8.4 Load Capacity

Load mass applicable to robot is specified for each model and includes the mass of tool, etc. Applicable load torque and moment of inertia around wrist axes (JT4, JT5, and JT6) are also specified. Strictly observe the following restrictions on them.

! CAUTION

Using the robot beyond its specified load may result in degradation of movement performance and shortening of machine service life. The load mass includes the tool mass such as hand, tool changer, shock absorber, etc. If using the robot in excess of its load capacity, first contact Kawasaki without fail.

The load torque and the moment of inertia can be calculated by the expression below:

Calculation Expression

The diagram illustrates a load mass M (kg) represented by a grey circle. A vertical line indicates the distance L_6 (m) from the rotation center of axis JT6 to the load. A horizontal line indicates the distance $L_{4,5}$ (m) from the rotation center of axis JT4(5) to the load. A curved arrow labeled I_G represents the moment of inertia around the center of gravity of the load.

Load mass : $M \leq M_{max}.$ (kg)
(including tools)

Load torque : $T=9.8 \cdot M \cdot L$ (N·m)

Load moment of inertia : $I = M \cdot L^2 + I_G$ (kg·m²)

M_{max} : Maximum load mass: See 3.2.

L : Length from axis rotation center to load center of gravity (Unit: m) (See the figure.)

$L_{4,5}$: Length from JT4(5) axis rotation center to load center of gravity

L_6 : Length from JT6 axis rotation center to load center of gravity

I_G : Moment of inertia around center of gravity (Unit: kg·m²)

If calculation of load is made by dividing the load into construction parts, such as tools and workpieces, use the total calculation values of each part as load torque and moment of inertia.

Regarding the load on the robot wrist section, strictly observe the following restriction:

1. The load mass including tool mass should be less than the following value.

Model	Max. load mass
BX100L	100 kg
BX130X	130 kg
BX165N, BX165L	165 kg
BX200L	200 kg

2. The load torque and the moment of inertia around each wrist axis (JT4, JT5, JT6) should be within the following restriction.

⚠ CAUTION

Set the load data via Auxiliary function 0304 after mounting of tools without fail. Operating robot with wrong settings may cause vibrations in motion, degradation of movement performance and shortening of machine service life.

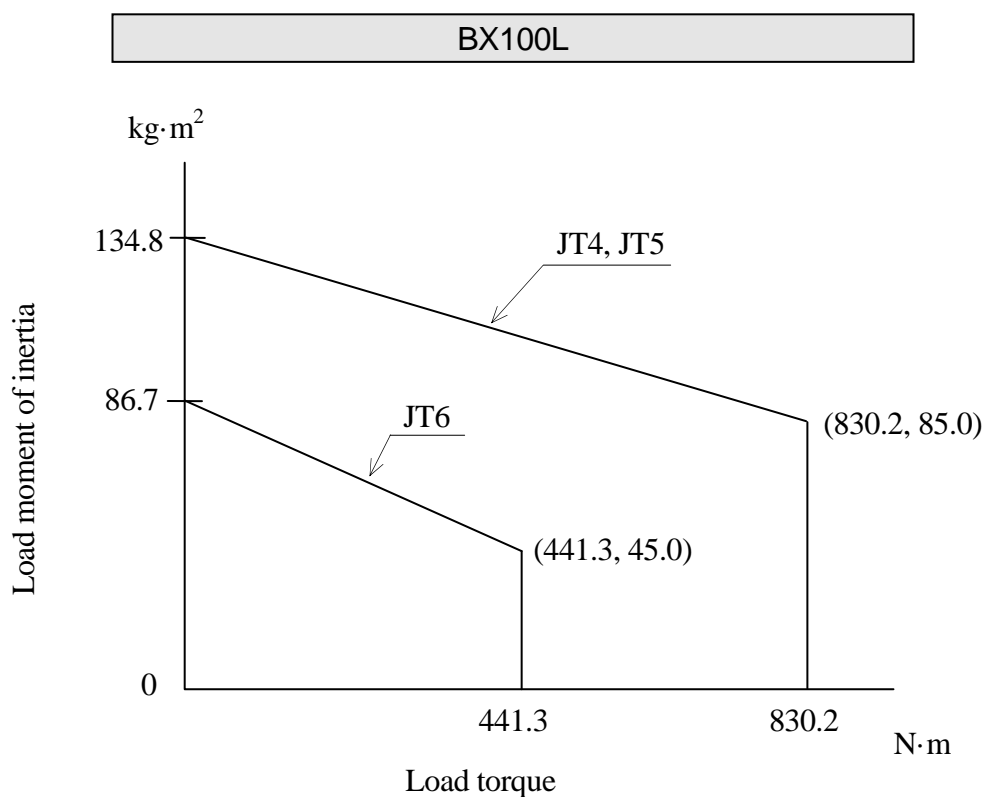

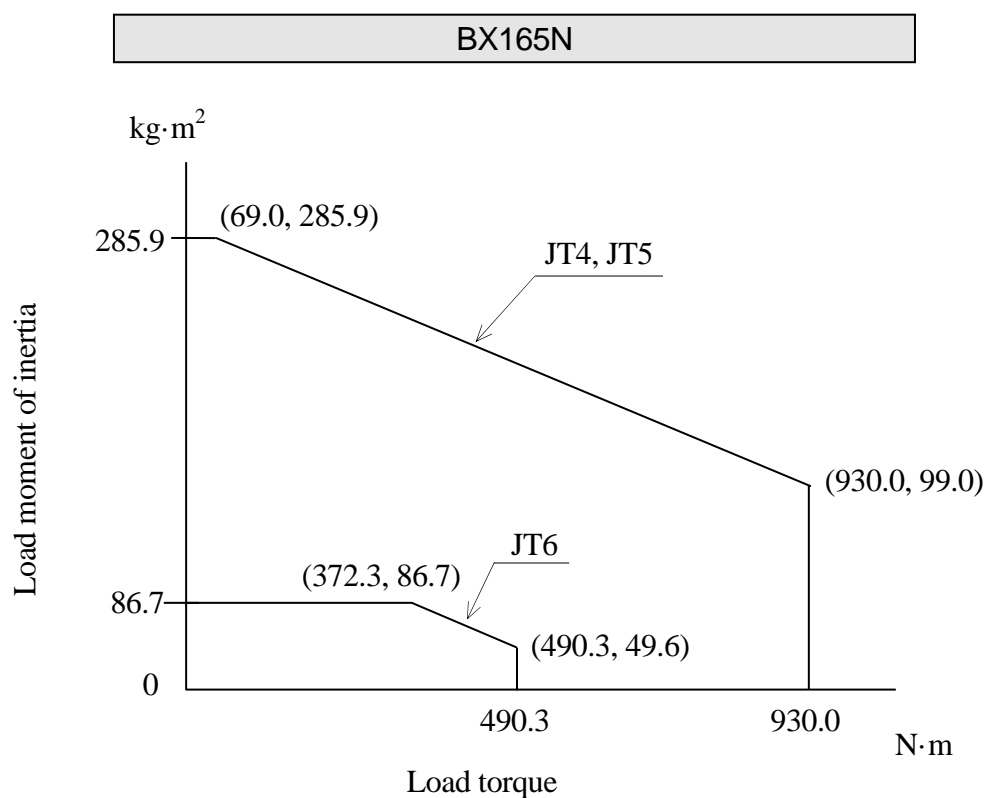
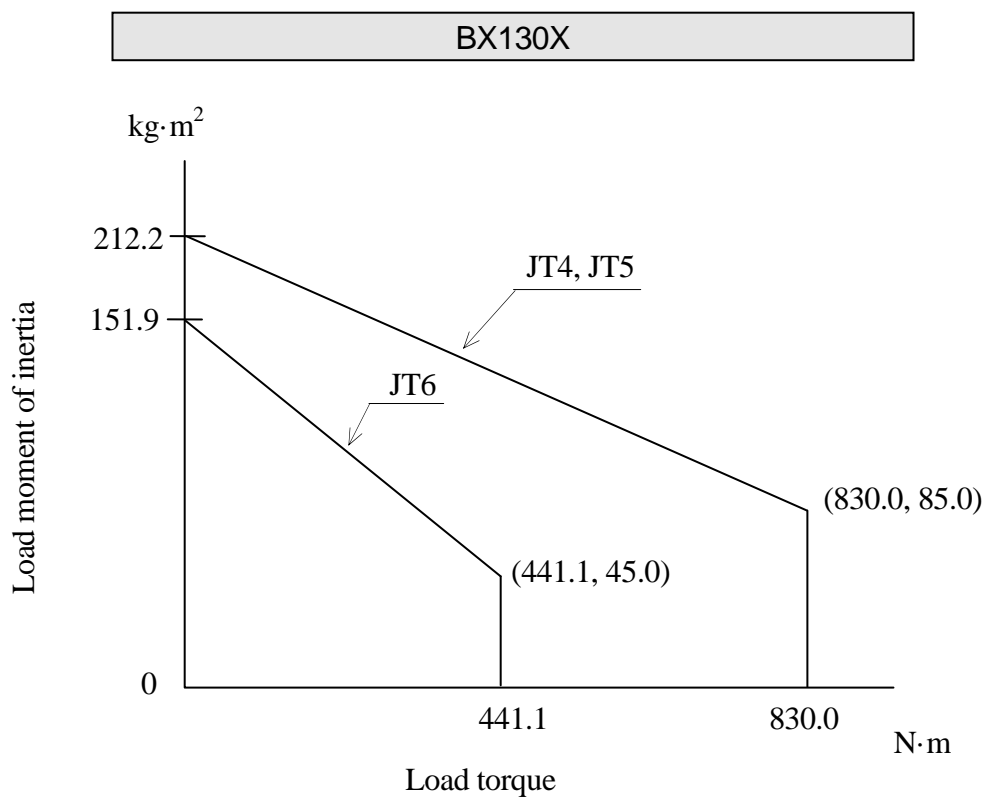

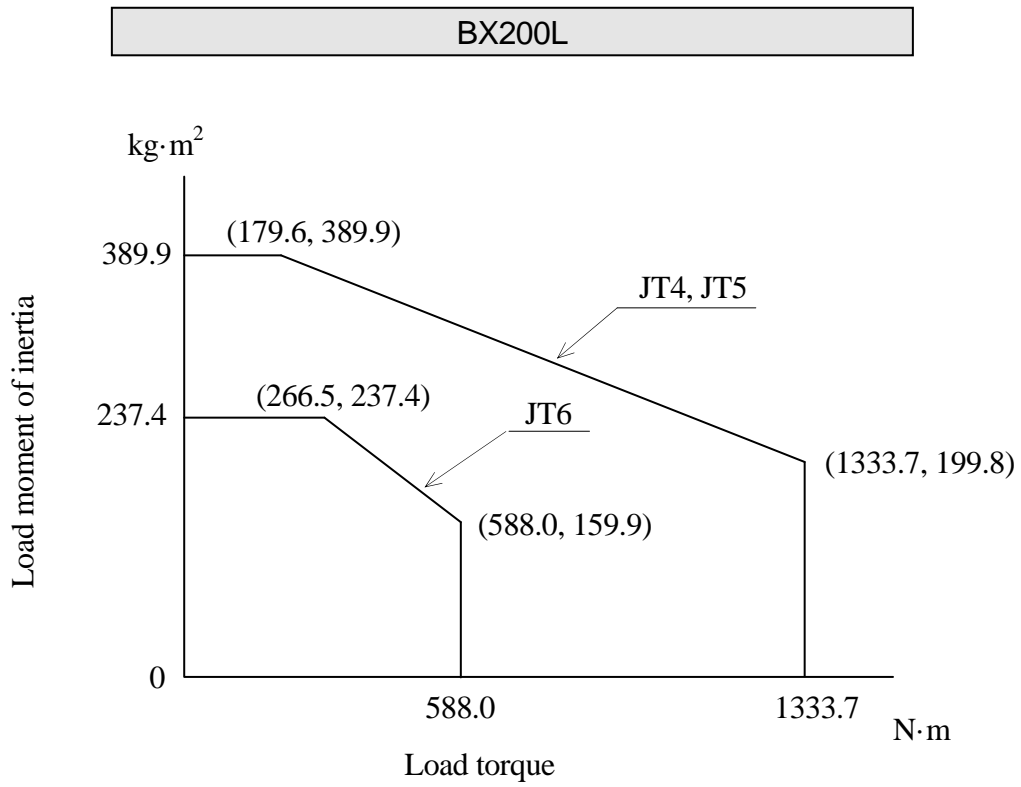
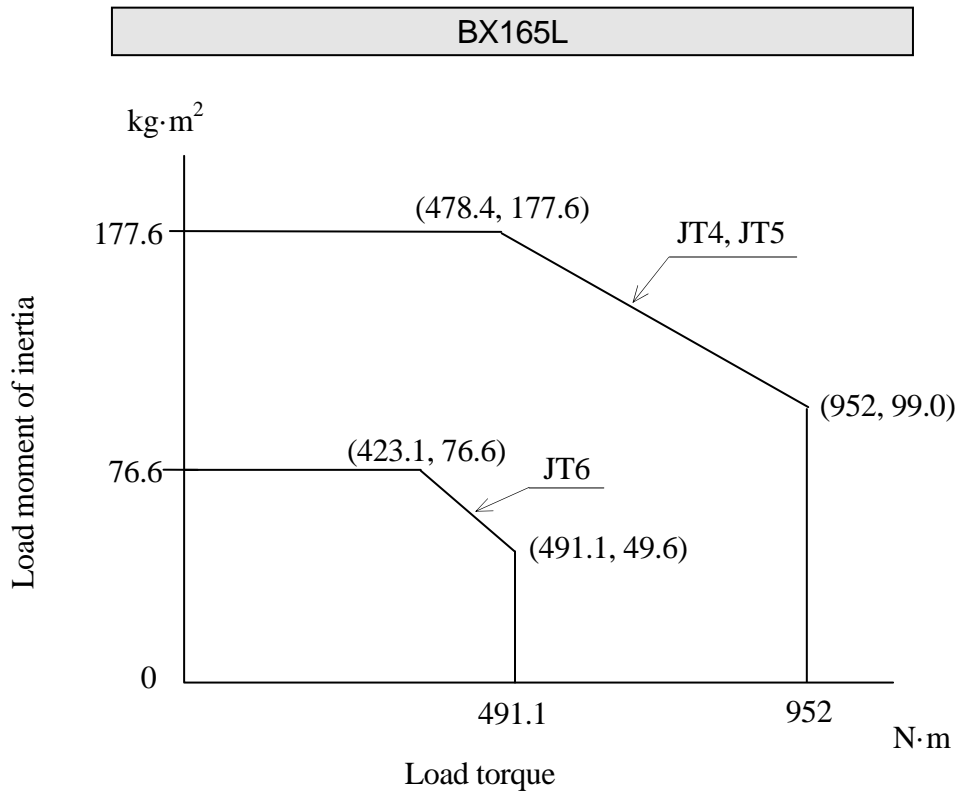

9 Mounting External Equipment

9.1 Service Tapped Hole Positions

Service tapped holes shown in the figure below are available to mount wiring brackets and external equipment on each part of robot arm.

! CAUTION

Check the robot movement very carefully and confirm that mounted brackets and external equipment do not interfere with peripheral equipment and robot arm itself.

BX100L, BX130X, BX165N, BX165L, BX200L

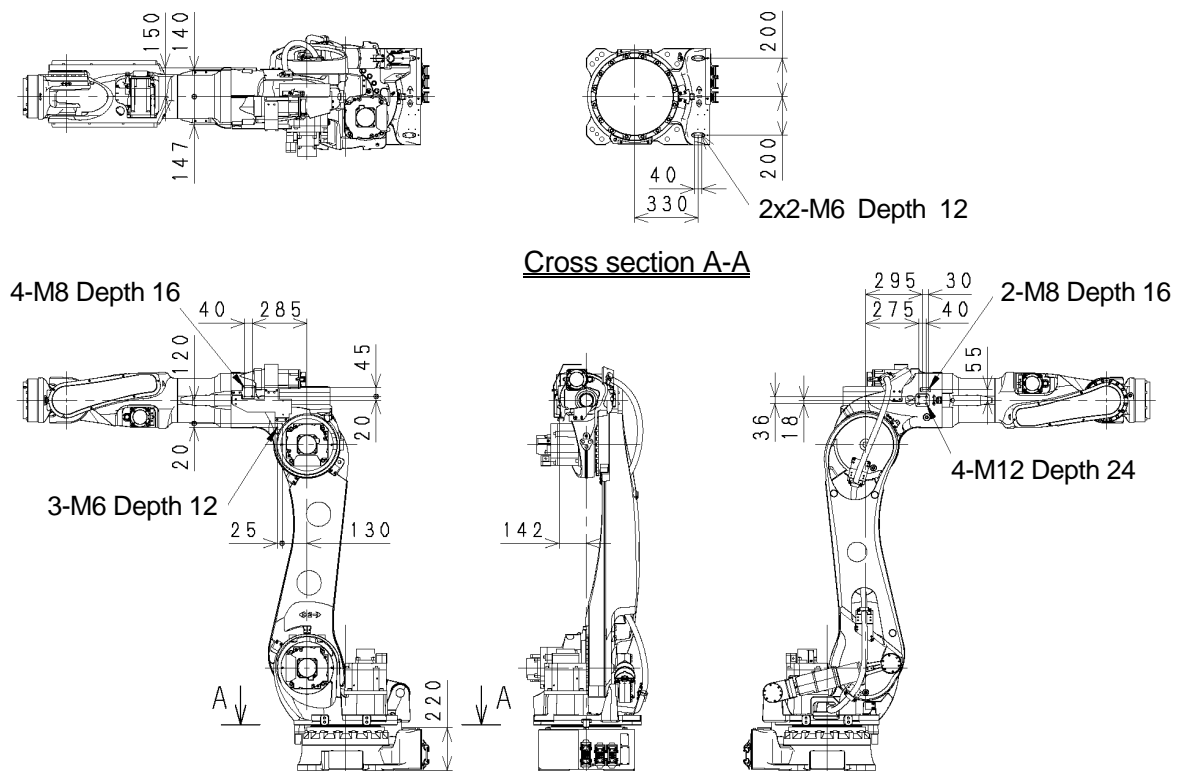

9.2 Calculation of Load Caused by External Equipment

The load capacity is set for each robot model. Strictly observe the following restrictions of the load torque and load moment of inertia on arm.

! CAUTION

Using the robot beyond its specified load capacity may result in degradation of movement performance and shortening of machine service life. If the load exceeds load capacity, first contact Kawasaki without fail.

For JT2 and JT3, limit the total load torque on wrist end and arm not to exceed the maximum allowable load torque. The load torque and the moment of inertia can be calculated by the expression below.

Calculation Expression

BX100L, BX130X, BX165N, BX165L, BX200L

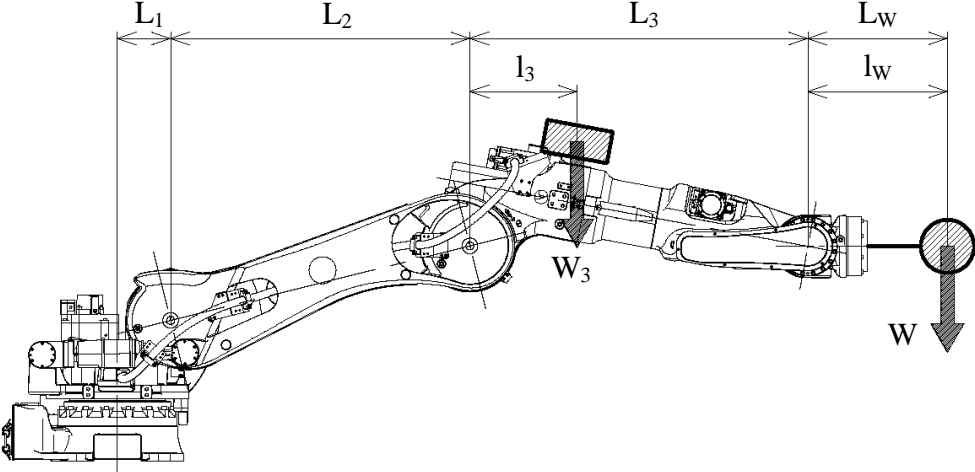

$$\left\{ \begin{array}{l} \bullet \text{JT3: } W(L_3+l_w)+W_3 \cdot l_3 \leq W_{\max}(L_3+L_w) \\ \bullet \text{JT2: } W(L_2+L_3+l_w)+W_3(L_2+l_3) \leq W_{\max}(L_2+L_3+L_w) \end{array} \right.$$

W_{\max} : Max. allowable load [kg]
 W : Load on wrist end [kg]
 W_3 : Total load on upper arm [kg]
 l_w : Position of the center of the gravity for load on wrist section [mm]
 l_3 : Position of the center of the gravity for total load on upper arm [mm]

Use data in the table below for calculation.

	L ₁ [mm]	L ₂ [mm]	L ₃ [mm]	L _w [mm]	W _{max} [kg]
BX100L	200	1126	1271	847	100
BX130X	200	1126	1666	651	130
BX165N	200	854	1271	575	165
BX165L	200	1126	1271	674	165
BX200L	200	1126	1271	680	200

However, do not exceed the value below for W₃.

$$W(L_1+L_2+L_3+l_w)+ W_3(L_1+L_2+l_3) \leq W_{max}(L_1+L_2+L_3+L_w)$$



CAUTION

W₃, W, l₃ and l_w are set as default in shipment. When using a robot for the first time or when changing the load mass or the position of the gravity center of the load, set the W₃, W, l₃ and l_w via Auxiliary 0304 and 0404. Operating robot with wrong settings may cause vibrations in motion, degradation of movement performance and shortening of machine service life.

Kawasaki Robot B Series (Ver. C)
Installation and Connection Manual

2017-05 : 1st Edition

2018-05 : 2nd Edition

Publication : Kawasaki Heavy Industries, Ltd.

90202-1180DEB

Copyright © 2017 Kawasaki Heavy Industries, Ltd. All rights reserved.